

15. TOP(FRONT) - Exploded View

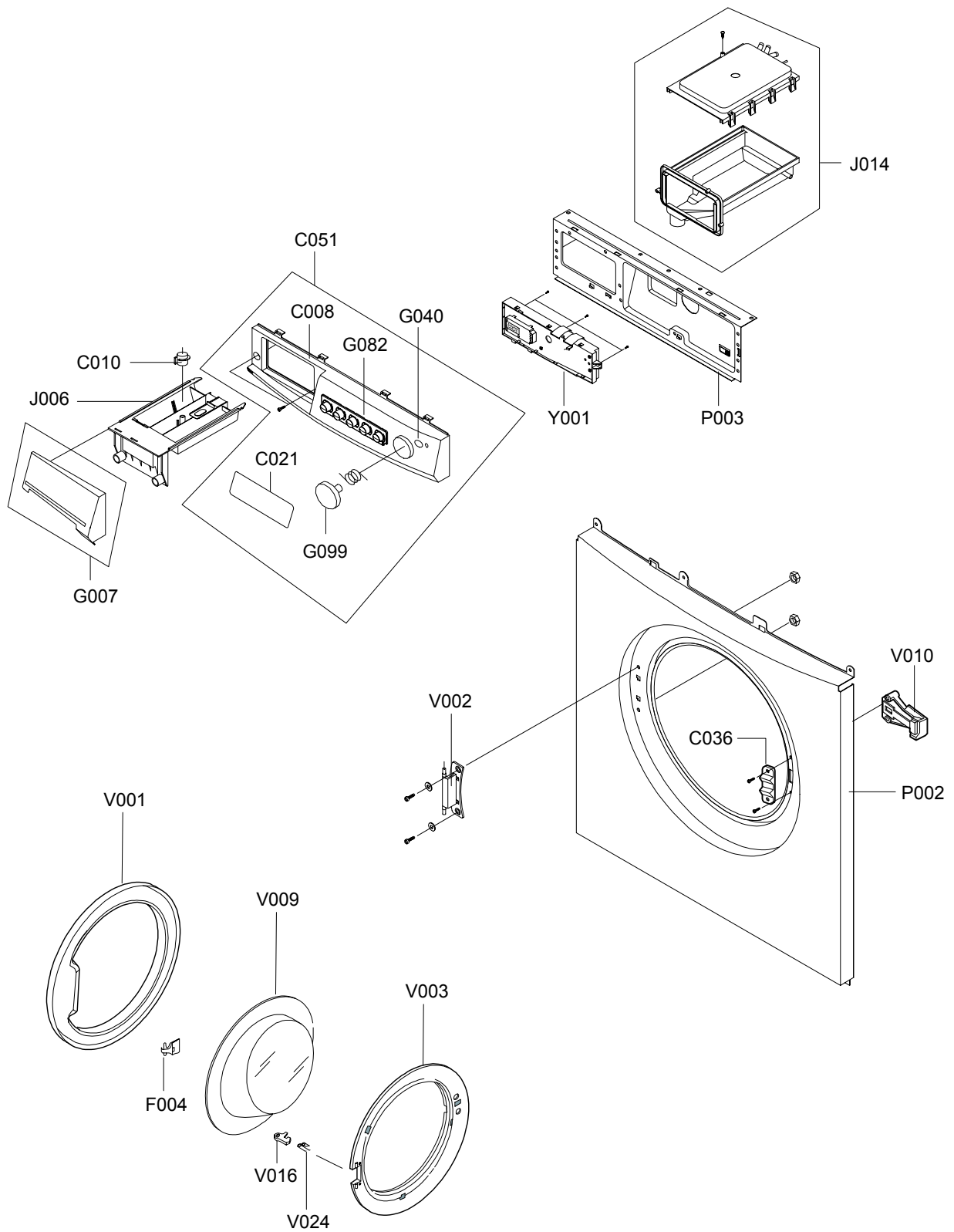

15. TUB - Exploded View

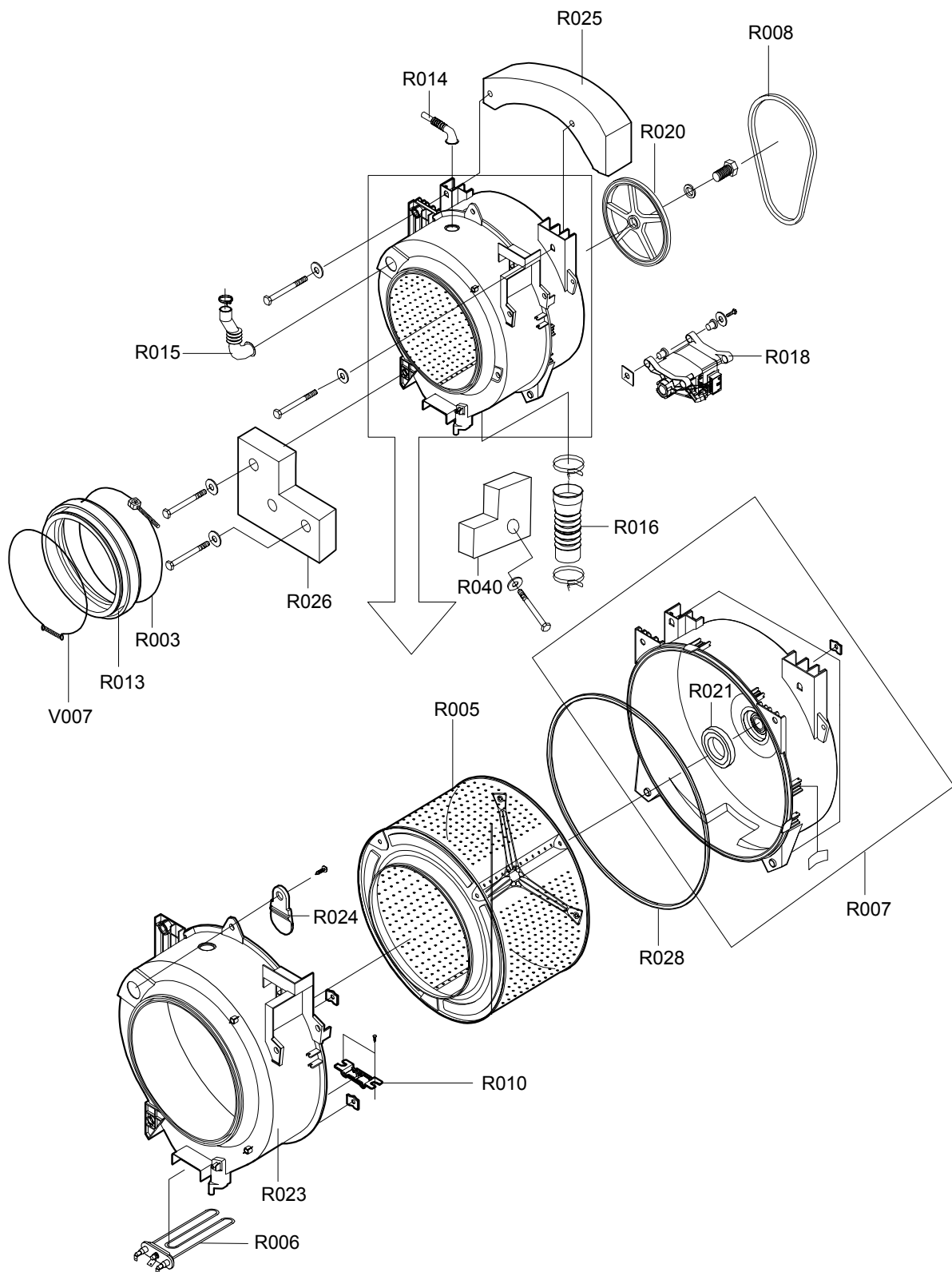
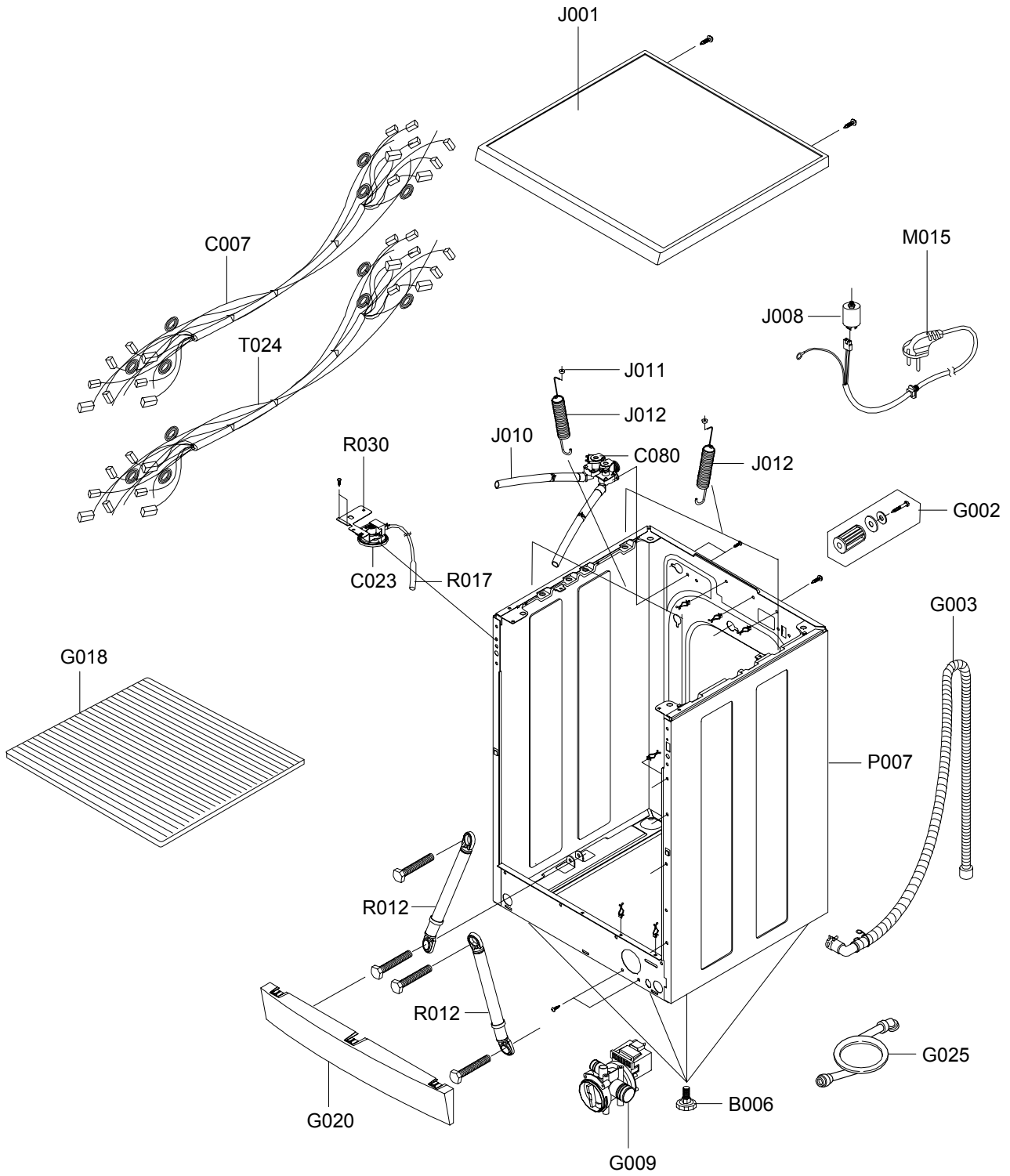

15. CASE - Exploded View



15. Parts List

NO.	CODE NO.	DESCRIPTION;SPECIFICATION	QTY
B006	DC97-02079C	ASSY-LEG;SB-PJT,SLIM/25MM/CHINA	4
C007	DC96-00625A	ASSY-M.WIRE HARNESS;SD405,ROLD-DOOR	1
C008	DC64-00814D	PANEL-CONTROL;F1043GW/YLP,ABS,-,-,-,WH	1
C010	DC61-10316B	CAP-RINSE;SEW-740DR,PP(TB-52),-,-,-,WHT,	1
C021	DC64-00864A	INLAY-PANEL;R(P/F/S)1043,PC,T0.5,-,-,WHT	1
C023	DC32-30006P	SENSOR PRESSURE;DN-S14(P1291),TERMINAL-T	1
C036	DC63-00450A	COVER-FRONT;S821,PP,T1.8,-,-,-,WHT,GUI	1
C051	DC97-07427D	ASSY-PANEL CONTROL;MID-PJT/F1043,WHT/RUS	1
C053	DC61-00889A	HINGE-DOOR;HAUZEN(DOM),ZNDC,-,-,-,-,18	1
C080	DC62-00024F	VALVE-WATER;B1215J,NYLON66/250TRMN,-,-,N	1
F004	DC64-00646A	HANDLE-DOOR;SD455-PJT,POM,-,-,-,WHT,RO	1
G002	DC97-02106A	ASSY-FIXER TUB;S1005J,SLIM-PJT	5
G003	DC97-00139E	ASSY-HOSE DRAIN(O);SB-PJT,PP/L1770/CHINA	1
G007	DC97-05469Y	ASSY-PANEL FRONT;MID-PJT/R(F/S),WHT/RUSS	1
G009	DC96-00149A	ASSY-PUMP DRAIN;P8091/P6091,220~240V/50H	1
G018	DC64-00434A	SHUTTER;F1215J/F-PJT,PP,-,-,-,WHT,-	1
G020	DC61-10672A	COVER-FRONT(L);SWF-P12,PP(BJ-730),-,-,-,	1
G025	DC62-10289B	HOSE-WATER(C);WIP4013SRW,PVC+NYLON,ID10.	1
G040	DC64-00812A	BUTTON-PUSH(P);P/R/F/SLIM,ABS,-,-,SNOW-W	1
G082	DC64-00813A	BUTTON-PUSH(F);P/R/F/SLIM,ABS,-,-,SNOW-W	1
G099	DC64-00811A	BUTTON-PUSH(S);P/R/F/SLIM,ABS,-,-,SNOW-W	1
J001	DC97-00851T	ASSY-COVER TOP;F-PJT,WOOD/MDF/SLIM 40CM	1
J006	DC61-00366A	BODY-DRAWER;SL-600,TB-53,-,-,-,-,-	1
J008	DC29-00006B	FILTER-EMI;CDFC-2712R,SLIM,250V,12A,PI38	1
J010	DC67-00051A	HOSE-DRAWER;S1093~S6093,EPDM,-,-,-,-,BLK	0.38
J011	DC61-60180A	SLEEVE-PLUG;NYLON#6,SEW-720DR,-,-,NTR	4
J012	DC61-00708A	SPRING-HANGER;F-PJT,HSWR,CD2.8,-,-,L170,	2
J014	DC97-06572B	ASSY-HOUSING DRAWER;F-PJT,2WAY/COLD/VALV	1
J014	DC97-02132C	ASSY-HOUSING DRAWER;S1093~S6093/2-WAY,SL	1
M015	DC96-00146A	ASSY POWER CORD;UCP2,-,250V/16A,-,-,-,-,	1
P002	DC97-00702A	ASSY-FRAME FRONT;P6091,ROUND-TYPE	1
P003	DC97-00417A	ASSY-FRAME PLATE(U);SWF-P12,FRAME-PLATE(1
P007	DC99-00298A	ASSY-PAINT FRAME;F813J,COLD/F-MODEL	1
R003	DC91-12077A	ASSY-CLAMP DIAPHGRAM;SWF-P12,TUB	1
R005	DC97-01463J	ASSY-DRUM;F-PJT/SD-PJT/LIFTER,STS430/FIX	1
R006	DC47-00006B	HEATER;KAWAI,P-SLIM MODEL,SUS316L,-,-,23	1
R007	DC97-00214K	ASSY-TUB BACK;SWF-P8/P6091,LOW-RPM/NO.3	1
R008	6602-001072	BELT-TIMING GEAR;POLYURETHAN,L1270,J5,ME	1

15. Parts List

NO.	CODE NO.	DESCRIPTION;SPECIFICATION	QTY
R010	DC61-00856A	BRACKET-HEATER;SB-PJT,STS430,-,-,-,-	1
R012	DC66-00320A	DAMPER-SHOCK;SB-PJT,ABS,-,-,-,-,WHT,AKS-	2
R013	DC64-00374A	DOOR-DIAPHRAGM;F1225J,EPDM,-,-,-,-,GRY,-	1
R014	DC62-10303A	HOSE-AIR;-,-,EPDM,ID24,-,-,L130,BLK,SWF-P1	1
R014	DC62-10272D	HOSE-AIR;S621,PVC,ID4.5,-,-,L520,NTR,-	1
R015	DC62-10305A	HOSE-DRAWER TUB;-,-,EPDM,ID35,-,-,L158,BLK	1
R016	DC62-00121A	HOSE-FILTER TUB;S1005J,EPDM,ID65,-,-,-,-	1
R017	DC67-00107A	HOSE-PRESSURE;S821,PE-BLOW,ID13.2,OD6.2,	1
R018	DC31-00002E	MOTOR-DRUM;HXGN2I.02,SFW-P8,-,-,50Hz,-,-,L	1
R020	DC66-00060A	PULLEY;FRPP,-,-,D297,SWF-PV2,ID12.5	1
R021	DC62-00007A	SEAL-OIL;-,-,NBR(SD25),BLK,-,-,-,-,P6091/NBU	1
R024	DC62-20311A	VANE-CHECK;SWF-P12,EPDM,-,-,BLK,-,	1
R025	DC67-00038A	WEIGHT-BALANCER;F-PJT(40CM),CONCREET,-,-,-	1
R026	DC67-00042B	WEIGHT-BALANCER;F1215,GC-150(CHINA),-,-,-,	1
R028	DC62-40183A	PACKING-TUB;SWF-P12,EPDM,-,-,-,-,-,BLK,-	1
R040	DC67-00050B	WEIGHT-BALANCER;F-1215,GC-150,-,-,-,-,-,F-	1
R074	DC61-00365B	TUB-FRONT;SL-600,FRPP(GR15%)SAMBAK,-,-,-,-	1
T024	DC96-00626A	ASSY-WIRE HARNESS;SD405,SUB(HIGH)	1
T031	DC61-00041A	CUSHION-MOTOR;SWF-6V,BUTYL,-,-,-,-,-,ID16/OD	1
V001	DC63-00391A	COVER-DOOR;HAUZEN(DOM),ABS,-,-,-,-,-,WHT	1
V007	DC91-12078A	ASSY-WIRE DIAPHRAGM;SWF-P12,FRAME-FRONT	1
V009	DC61-00013A	DOOR-GLASS;GLASS,NTR,SWF-P12	1
V016	DC66-00358A	LEVER-DOOR;SEW-HW105,ZNDC,-,-,-,-,-,CR-COA	1
V024	DC61-00890A	SPRING-HANDLE;HAUZEN(DOM),STS304,CD1.0,-	1
V031	DC61-00888A	HOLDER-GLASS;HAUZEN,ABS,-,-,-,-,-,WHT,AUTO+M	1
Y001	MFS-F1043-00	ASSY PCB PARTS;F1043 40CM 4.5KG 1000RPM	1

Screw/Bolt List

CODE NO.	DESCRIPTION	SPECIFICATION	REMARK	QTY
6001-001773	SCREW-MACHINE	TH,+,M5,L12,	HINGE+FRAME	2
6002-001006	SCREW-TAPPING	TH,+,2S,M4,L12,-,STS410	DOOR-S/W	2
6002-001006	SCREW-TAPPING	TH,+,2S,M4,L12,-,STS410	-	11
6002-000213	SCREW-TAPPING	TH,+,1,M4,L12,ZPC(YEL),SWRCH18	CLAMP-HOSE+FRAME	1
6002-000239	SCREW-TAPPING	TH,+,2S,M4,L8,ZPC(YEL),SM20C	FRAME+FRAME-FRONT	7
6002-000239	SCREW-TAPPING	TH,+,2S,M4,L8,ZPC(YEL),SM20C	FRAME+PLATE-UPPER	4
6002-000525	SCREW-TAPPING	FH,+,1,M4,L12,PASS,STS304	C-PANEL+FRAME	1
6002-000554	SCREW-TAPPING	PH,+,2S,M4,L12,ZPC(YEL),SWRCH1	PCB+C-PANEL	3
6002-001006	SCREW-TAPPING	TH,+,2S,M4,L12,-,STS410	PUMP+FRAME	2
6002-001327	SCREW-TAPPING	PWH,+,1,M4,L12,NI PLT	SHUTTER	2
6006-001170	SCREW-TAPPING	WS,TH,+,M4,L10,ZPC(YEL)	E/W(SUB)+FRAME(F)	1
6006-001170	SCREW-TAPPING	WS,TH,+,M4,L10,ZPC(YEL)	FILTER-EMI	1
6009-001343	SCREW-SPECIAL	PH,TORX,,M4,L10,PASS	P/CORD	1
DC60-40144A	BOLT-HEX	M10,L41,ZPC2(YEL),SM10C/DAMPER	DAMPER+FRAME	2
DC60-40146A	BOLT-SPANER	-,-,OD36,T2.5,L52,FE,FZY,-,P12	ACCESSORY	1
6011-001421	BOLT-FLANGE	M7,L61(29.4),ZPC(YEL),SWRCH18A	-	1
DC60-60040A	WASHER-NYLON	-,ID10.5,OD32,T2,-,PBSP-1/2H	FIXER	1
DC60-60044B	WASHER-PLAIN	SBC,ID8.4,OD30,T3,-,-,-	FIXER	1
6002-000239	SCREW-TAPPING	TH,+,2S,M4,L8,ZPC(YEL),SM20C	MAIN PCB1	1
6002-000239	SCREW-TAPPING	TH,+,2S,M4,L8,ZPC(YEL),SM20C	MAIN PCB2	1
6002-000630	SCREW-TAPPING	PH,+,2S,M3,L8,ZPC(YEL),SWRCH18	BD1	1
6002-000630	SCREW-TAPPING	PH,+,2S,M3,L8,ZPC(YEL),SWRCH18	TRIAC1	1
6002-000445	SCREW-TAPPING	TH,+,2S,M4,L18,NTR,STS304	PANEL+FRM+HOUSING-D	2
6002-000554	SCREW-TAPPING	PH,+,2S,M4,L12,ZPC(YEL),SWRCH1	HOUSING-DRAWER	1
6002-001327	SCREW-TAPPING	PWH,+,1,M4,L12,NI PLT	C/TOP+FRAME	2
6003-000226	SCREW-TAPTITE	TH,+,S,M4,L8,ZPC(YEL),SWRCH18A	W/V+FRAME	2
6006-001170	SCREW-TAPPING	WS,TH,+,M4,L10,ZPC(YEL)	B/K-PRESSURE+FRAME	1
6006-001170	SCREW-TAPPING	WS,TH,+,M4,L10,ZPC(YEL)	P/CORD(E/W)	1
6009-001342	SCREW-SPECIAL	TH,+,M5,L11,ZPC(YEL)	FRAME(TOP)	2
6002-000630	SCREW-TAPPING	PH,+,2S,M3,L8,ZPC(YEL),SWRCH18	B/K+PRE-S/W	2
6002-000470	SCREW-TAPPING	TH,+,1,M4,L10,ZPC,SCRCH18A	B/K-C.T	2
6011-001421	BOLT-FLANGE	M7,L61(29.4),ZPC(YEL),SWRCH18A	WEIGHT(L)	1
6011-001447	BOLT-HEX	M8,L123(25),ZPC(YEL),SWRCH18A,WP,NYLOCK	WEIGHT(U)	1
6011-001448	BOLT-HEX	M8,L170(25),ZPC(YEL),SWRCH18A,WP,NYLOCK	WEIGHT(U)	1
6011-001452	BOLT-HEX	M10,L20,ZPC(YEL),SWCH10AK,ASSY(WS)	PULLEY	1
DC60-40141A	BOLT-HEX	SM10C/DAMPER,HEX,M8,L66,-,ZPC2(YEL)-,-	DAMPER+TUB	2
DC60-50148B	NUT-HEX	SM20C(NYLON),M12,-,-,ZPC3(YEL)-,-,HEX,P-PROJECT	PULLEY	1
DC60-60044A	WASHER-PLAIN	-,ID10.5,OD30,T3,-,STS304	DAMPER+TUB	2
DC61-00201A	BRACKET-NUT	SBHG-R,P1291,T3,-,-,-,NO-PAINT/MOTOR	MOTOR	1
6006-001170	SCREW-TAPPING	WS,TH,+,M4,L10,ZPC(YEL)	-	1
DC61-40348B	BRACKET-NUT	SBHG-R,P1291,T3,-,-,-,NO-PAINT	-	2
6011-001492	BOLT-FLANGE	M8,L25,PASS,STS304,NYLOCK,P1.25	-	3
6002-000444	SCREW-TAPPING	TH,+,2S,M4,L14,NTR,STS304	B/K-HEATER	2
6002-000471	SCREW-TAPPING	TH,+,1,M4,L12,PASS,STS304,-	VANE-CHECK	1
DC61-00201A	BRACKET-NUT	SBHG-R,P1291,T3,-,-,-,NO-PAINT/MOTOR	-	1
DC61-40348B	BRACKET-NUT	SBHG-R,P1291,T3,-,-,-,NO-PAINT	-	2
DC60-40005A	BOLT-HEX	M4,L60,ZPC2(YEL),SS41C,-,-,-,-	-	1
DC60-50010A	NUT-DIAPHRAGM	EGI,M4,-,-,2.5TX20X8	-	1
DC60-50010B	NUT-DIAPHRAGM	EGI,M4.2,-,-,2.5TX20X8	-	1
DC97-02412A	ASSY-BOLT	SWF-P12,MOTOR, M8*L62	MOTOR	1
DC97-02412A	ASSY-BOLT	SWF-P12,MOTOR, M8*L62	WEIGHT BALANCE(R)	1
DC97-02412A	ASSY-BOLT	SWF-P12,MOTOR, M8*L62	WEIGHT-BALANCER(L)	1
DC99-00297A	ASSY-PAINT	F813J/F-PJT,ROUND-TYPE/COLD	-	1
6002-000213	SCREW-TAPPING	TH,+,1,M4,L12,ZPC(YEL),SWRCH18	-	1



This Service Manual is a property of Samsung Electronics Co.,Ltd.
Any unauthorized use of Manual can be punished under applicable
International and/or domestic law.

©Samsung Electronics Co., Ltd. 2004 MAY
Printed in Korea
Code No. : DC68-02189A